

# Clarke®

## X-PRO



### 1/2" AIR IMPACT WRENCH

MODEL NO: CAT198

PART NO: 3120515

## OPERATING & MAINTENANCE INSTRUCTIONS

UK  
CA | CE

ORIGINAL INSTRUCTIONS

GC02/22 Rev1

---

## INTRODUCTION

---

Thank you for purchasing this CLARKE Impact Wrench.

Please read all of the safety and operating instructions carefully before using this product. In doing so you will ensure the safety of yourself and that of others around you and you can look forward to your purchase giving you long and satisfactory service.

**Please keep these instructions in a safe place for future reference.**

---

## SPECIFICATION

---

CAT198	Part no 3120515
Dimensions (L x W x H)	197 x 190 x 68 mm
Weight(s)	2.49 kg
Drive size	½" square
Air Inlet Size	¼" BSP female
Max operating air pressure	90 psi (6.3 bar)
Air Consumption	average 6.5 cfm
Max Torque	650 ft/lbs (reverse 670 ft/lbs)
Max No Load Speed	8000 rpm @ 90 psi
Torque at settings 1-4	
Forward 1	185 ft/lbs
Forward 2	330 ft/lbs
Forward 3	650 ft/lbs
Reverse 4	670 ft/lbs
Sound Pressure Level (LpA dB)	77 dB(A)
Sound Power Level (LwA dB)	88 dB(A)
Vibration Level	6.096 m/s <sup>2</sup> (uncertainty factor K= 1.5 m/s <sup>2</sup> )

---

## GENERAL SAFETY RULES

---



CAUTION: FAILURE TO FOLLOW THESE PRECAUTIONS COULD RESULT IN PERSONAL INJURY, AND/OR DAMAGE TO PROPERTY.

---

### THE WORK ENVIRONMENT

1. ALWAYS keep the work area clean and tidy.
2. ALWAYS dress appropriately - Do not wear loose clothing or jewellery. Tie long hair out of the way.
3. ALWAYS keep children and visitors away - Do not let children handle the wrench
4. DO NOT operate where there are flammable liquids or gases.

### USE OF COMPRESSED AIR TOOLS

1. Stay alert and use common sense - do not use the wrench when you are tired or under the influence of alcohol, drugs or medication.
2. ALWAYS wear eye protectors when using the wrench. Eye protectors must provide protection from flying particles from the front and the side. Ear protectors should also be worn.
3. DO NOT overreach - Keep proper footing and balance at all times.
4. NEVER use oxygen, CO<sup>2</sup>, combustible gases or any type of bottled gas as a source of power for any air tool.
5. DO NOT connect the air supply hose with your finger on the trigger.
6. DO NOT exceed the maximum pressure of 90 psi / 6.2 bar.
7. Keep the air supply hose away from heat, oil and sharp edges.
8. DO NOT fit any air tool to a stand or clamping device that may damage it.
9. Check hoses for leaks or worn condition before use and ensure that all connections are secure.
10. DO NOT use the tool for any purpose than that described in this manual.
11. DO NOT carry out any alterations or modifications to the tool.
12. Always disconnect from the air supply when:
  - Performing any maintenance.
  - The tool is not in use.

- The tool will be left unattended.
  - Moving to another work area.
13. NEVER use the tool if it is defective or operating abnormally.
  14. Avoid damaging the tool by applying excessive force.
  15. ALWAYS maintain the tool with care. Keep it clean for the best and safest performance.
  16. Quick change couplings should not be located at the tool. They add weight and could fail due to vibration.
  17. DO NOT force or misuse the tool. It will do a better and safer job at the rate for which it was designed.
  18. This air tool vibrates with use. Vibration may be harmful to your hands or arms. Stop using the tool if discomfort, a tingling feeling or pain occurs. Seek medical advice before resuming use.
  19. NEVER carry the wrench by the air hose.
  20. NEVER carry the wrench with your finger on the trigger.
  21. When not in use the wrench should be disconnected from the air supply and stored in a dry place out of reach of children.

## **IMPACT WRENCH SAFETY INSTRUCTIONS**

1. ALWAYS use the wrench as described in these instructions.
2. ALWAYS ensure the wrench is not moving and disconnected from the air supply when changing sockets etc. **Use only Impact Wrench sockets....DO NOT use standard sockets.**
3. ALWAYS finish tightening wheel nuts or engine components with a torque wrench or suitable spanner to the correct torque as recommended by the vehicle manufacturer.
4. ALWAYS avoid excessive use of the wrench. When tightening a nut or bolt, only allow the wrench to impact briefly to avoid over tightening.
5. ALWAYS ensure that the socket is correctly installed before switching on.
6. Only use sockets which are specified for impact wrench use.
7. Due to the possible presence of asbestos dust from vehicle brake linings, always wear suitable respiratory protection.
8. ALWAYS disconnect from the air supply when changing sockets or when the wrench is not required for immediate use to avoid accidental starting.
9. ALWAYS use both hands to control the impact wrench.
10. ALWAYS ensure the wrench has stopped before putting it down after use.

# COMPRESSED AIR REQUIREMENTS



**WARNING: COMPRESSED AIR CAN BE DANGEROUS. ENSURE THAT YOU ARE FAMILIAR WITH ALL PRECAUTIONS RELATING TO THE USE OF COMPRESSORS AND COMPRESSED AIR SUPPLY.**

A typical air line layout is shown below. If an automatic in-line filter/regulator is used, it will keep the air tool in good condition, but should be regularly checked and topped up with oil. CLARKE airline oil should be used and the lubricator adjusted to approx 2 drops per minute

Use only clean, dry, regulated compressed air as a power source.

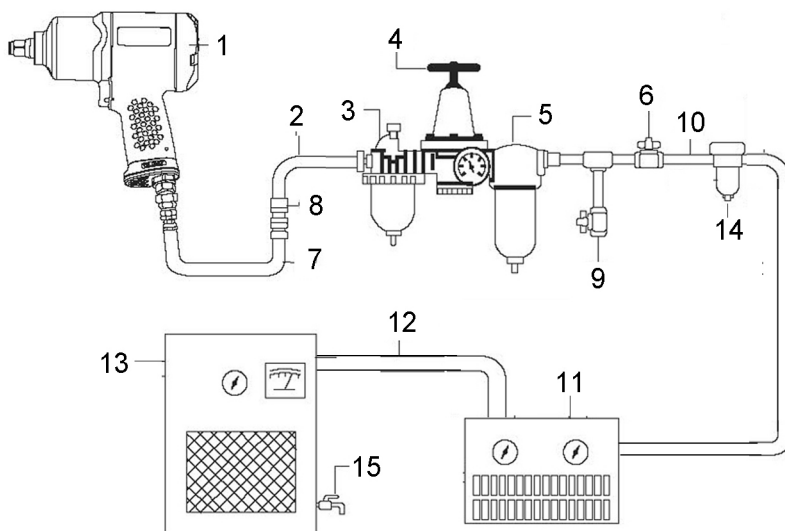

## AIR SYSTEM LAYOUT :

- |                               |                                     |
|-------------------------------|-------------------------------------|
| 1. Air Tool                   | 9. Drain Valve                      |
| 2. Air Hose 3/8" (I.D.)       | 10. 1/2" Or Larger Pipe And Fitting |
| 3. Oiler                      | 11. Air Dryer                       |
| 4. Pressure Regulator         | 12. 1" Or Larger Pipe And Fitting   |
| 5. Filter                     | 13. Air Compressor                  |
| 6. Shut Off Valve             | 14. Auto Drain                      |
| 7. Whip Hose                  | 15. Drain Valve                     |
| 8. Coupler Body And Connector |                                     |

A build-up of moisture or oil in the air compressor will accelerate wear and corrosion in the air tool. Ensure any moisture is drained from the compressor daily and the inlet filter is kept clean.

If an unusually long air hose is required, (over 8 metres), the line pressure or the hose inside diameter may need to be increased.

The air hose must be rated at least 150% of the maximum operating pressure of the air tool.

Never exceed the maximum operating pressure. It is recommended that air pressure does not exceed 90 psi (6.2 Bar) at the tool when running. Higher pressures and dirty air will shorten the life of the tool due to faster wear and is a possible safety hazard.

## PRODUCT OVERVIEW

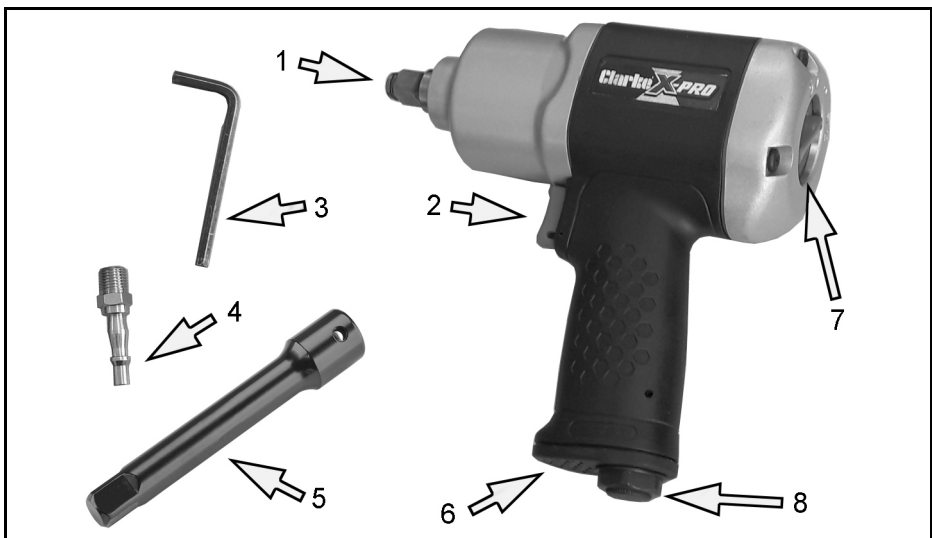

1	½" Square Drive shaft	5	Extension bar
2	Trigger	6	Air exhaust
3	Allen key	7	Direction/Speed Control
4	Inlet adaptor	8	Airline Inlet

---

## BEFORE USE

---



**WARNING: COMPRESSED AIR CAN BE DANGEROUS. ENSURE THAT YOU ARE FAMILIAR WITH ALL PRECAUTIONS RELATING TO THE USE OF AIR COMPRESSORS AND COMPRESSED AIR SUPPLY.**

---

**NOTE:** Ensure the compressor is turned off.

1. Remove the plastic blanking plug from the air inlet connection.
2. Pour 2-3 drops of CLARKE airline oil into the oil filling port. This should be done regardless of whether or not a lubricated air supply is to be used.
3. If required, connect an in-line mini oiler to the tool.
  - A mini oiler helps to prolong the life of any air tool.
4. If a mini-oiler is not being used, run a few drops of oil through the tool before use. It can be entered through the airline connector or via the hose at the nearest connection to the air supply.
5. Connect a suitable hose as shown or use the snap connector supplied to connect directly to the hose.
6. Connect the other end of the hose to the compressor.
7. Turn on the air supply and check for air leaks. Rectify any found before proceeding.
  - PTFE tape may be useful for sealing threaded connections.
8. If using a mini oiler, place a sheet of paper next the exhaust port and hold the throttle open for approximately 30 seconds. The oil volume is correctly set when a light stain of oil can be seen on the paper. Excessive oil should be avoided.



Your impact wrench is now ready for use.

You can fit a whip hose with a quick fit coupling if required, available from your CLARKE dealer.

---

# OPERATION

---

## FITTING THE IMPACT SOCKET

---



**WARNING: NEVER USE STANDARD SOCKETS. THESE MAY SHATTER WITH SERIOUS CONSEQUENCES. ONLY USE IMPACT SOCKETS DESIGNED FOR USE WITH IMPACT WRENCHES**

1. Select the impact socket you require, which must be in good condition and fit the tool exactly.
2. Push the socket onto the 1/2" square drive shaft as shown.
  - If required, the extension bar can be used when the nut is in an enclosed space.

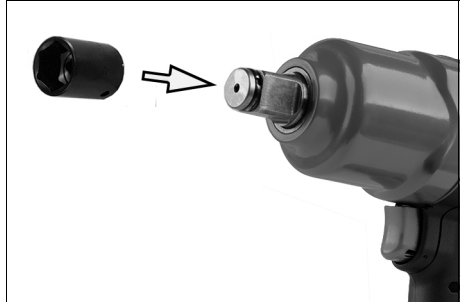

## ADJUSTING THE DIRECTION AND SPEED

1. To adjust the speed, turn the switch slowly forward until the desired output is achieved.
  - Setting 1 (small dot) is the least amount of power while setting 3 (large dot) is the most powerful.
  - The wrench operates at maximum power in reverse. This setting is for releasing threaded fasteners.

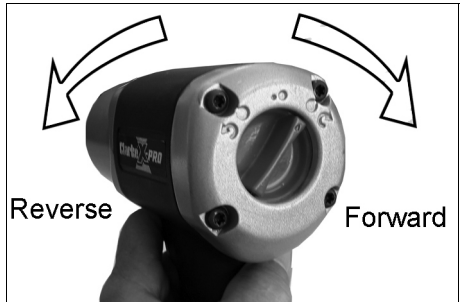

**NOTE:** Where the torque setting is critical, the final tightening must be by hand using a correctly calibrated torque wrench.



**WARNING: WAIT UNTIL THE WRENCH HAS STOPPED ROTATING BEFORE OPERATING THE FORWARD/REVERSE SWITCH.**



## LOOSENING A WHEEL NUT/BOLT

1. Remove any wheel trim, before selecting the appropriate socket and placing firmly on the square drive of the wrench.
2. With the control switch in the REVERSE running position (anti-clockwise) and holding the wrench firmly in BOTH HANDS, squeeze the trigger. The nut will be impacted repeatedly until it is loosened. **IMPORTANT!** Release the trigger as soon as the nut or bolt begins to loosen.
3. Jack up the vehicle according to the vehicles handbook so that the wheel is clear of the ground, then fully undo the wheel nuts/bolts.
4. Soak rusted nuts in penetrating oil, and break any rust seal before twisting off with the wrench.



**WARNING: ENSURE THAT THE CORRECT SOCKET IS BEING USED FOR THE NUTS ON YOUR PARTICULAR VEHICLE. USING AN INCORRECT SOCKET SIZE IS LIKELY TO DAMAGE THE HEADS OF THE BOLTS/NUTS.**

---

## TIGHTENING A NUT/BOLT

1. Start the nut/bolt by hand, ensuring it is not cross threaded, then with the appropriate socket installed on the wrench, place it on the nut./bolt.
2. With the selector switch in the clockwise (forward running) position and holding the wrench firmly in BOTH HANDS, pull the trigger.
3. Run each nut/bolt up in turn until it is 'nipped' up only - do not tighten. When all nuts/bolts are nipped up, tighten progressively by pulling the trigger fully and allowing the action to operate briefly to prevent overtightening.
4. ALWAYS finish tightening with a torque wrench. The weight of the vehicle will need to be placed on the wheel to prevent it from rotating while the nuts are tightened. Ensure the final torque applied to the nuts/bolts meets the vehicle manufacturer's recommendations.
  - For torque values, see specification on page 2.

## DISCONNECTING THE AIR SUPPLY

1. DO NOT disconnect the air hose until the supply is isolated at a shut-off valve.
2. Once the pressure has been isolated, disconnect the air supply hose from the wrench.
3. Shut down the compressor at the end of the work session.

---

# MAINTENANCE

---



**WARNING: MAKE SURE THAT THE WRENCH IS DISCONNECTED FROM THE AIR SUPPLY BEFORE STARTING ANY CLEANING OR MAINTENANCE PROCEDURES.**

---

## DAILY

1. Before use, drain water from the airline filter and compressor.
2. If no airline lubricator or mini oiler is used, ensure that oil is applied to the tool on a daily basis through the air inlet connection. Run a few drops of oil through the tool before use. It may be entered into the tool air inlet, (ensuring the strainer is clear), or into the hose at the nearest connection to the air supply.
3. This procedure should be repeated after every two to three hours of use, or at the start of the working day.
4. Keep the body of the tool clean and free from debris.

## WEEKLY

1. Check the air inlet screen filter for blockage and clean if necessary.

## CLEANING & OVERHAUL

1. Grit or gum deposits in the tool may reduce efficiency.
2. After extensive use, remove the inlet screen filter and flush out the mechanism with gum solvent oil or an equal mixture of CLARKE air-line oil and paraffin. Allow to dry before use.
3. If the tool still runs erratically or becomes inefficient, and the air supply is of good quality, it may be necessary to dismantle the air motor and replace worn or damaged parts. You may prefer to take the tool to your CLARKE dealer if internal maintenance is required.
4. The air tool may be dismantled by unfastening the bolts and removing the rear cover prior to replacing any worn or damaged parts.
5. While in a dismantled state, it may be desirable to grease the hammer mechanism and applying a small amount of good quality bearing grease.
  - This may be better left to your CLARKE dealer.

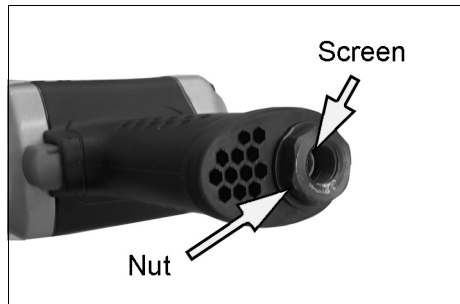

## TROUBLESHOOTING

SYMPTOM	PROBLEM	SOLUTION
Tool runs at normal speed but slows down under any load.	<ol style="list-style-type: none"> <li>1. Air motor parts worn.</li> <li>2. Worn or sticking mechanism due to lack of lubricant.</li> </ol>	<ol style="list-style-type: none"> <li>1. Return to CLARKE dealer for repair.</li> <li>2. Drip air tool lubricating oil into air inlet. Allow oil to soak moving parts before using.</li> </ol>
Tool runs slowly. Air flows weakly from exhaust.	<ol style="list-style-type: none"> <li>1. Air motor parts jammed with gum/ dirt.</li> <li>2. Air-line regulator in closed position.</li> <li>3. General airflow blocked by dirt.</li> </ol>	<ol style="list-style-type: none"> <li>1. Examine inlet air filter for blockage and clean if necessary. Drip a few drops of air tool lubricating oil into air inlet.</li> <li>2. Adjust in-line regulator to open position.</li> <li>3. Operate tool in short bursts.</li> </ol>
Tool will not run. Air flows freely from exhaust.	<ol style="list-style-type: none"> <li>1. Air motor vanes stuck due to buildup of foreign material.</li> </ol>	<ol style="list-style-type: none"> <li>1. Disconnect air supply and rotate tool assembly manually.</li> <li>2. Try operating tool in short bursts.</li> <li>3. Tap motor housing gently with a rubber mallet.</li> <li>4. Drip a few drops of air tool lubricating oil into air inlet to soak moving parts.</li> </ol>
Tool will not shut off.	<ol style="list-style-type: none"> <li>1. Throttle O-rings damaged or ill-fitting in seat.</li> </ol>	<ol style="list-style-type: none"> <li>1. Return to CLARKE dealer for repair.</li> </ol>

## PERFORMANCE

Please note that outside factors may effect the operation and efficiency of any air tool.

These include reduced compressor output, excessive drain on the airline, moisture ingress, restrictions in the air-line such as the use of connectors of incorrect size or poor condition which will reduce the air supply.

Your air tool has been designed to give long & trouble free service. If, however, having followed the instructions in this booklet carefully, you encounter problems, take the unit to your local CLARKE dealer.

Any major servicing and repairs should be carried out by your local CLARKE dealer or a qualified service technician.

## **STORAGE**

If the air tool is to be stored, or is idle for longer than 24 hours, run a few drops of CLARKE air line oil into the air inlet, and run the tool for 5 seconds in order to lubricate the internal parts. Store the tool safely in its box in a dry, secure environment.

When storing, replace the blanking plug on the airline inlet once the airline has been disconnected.

Avoid storing the wrench where the temperature is below 0°C.

## **ACCESSORIES**

A wide range of accessories is available including filter/regulators, lubricators, high-pressure hoses (5 to 50 metres) etc.

CLARKE Air Line Oil (part no. 3050825) is available from your CLARKE dealer.

### **SUITABLE CLARKE IMPACT SOCKET SETS INCLUDE:**

CIS12/11 11 piece 1/2" Metric Impact Socket Set part no 3110437

CIS12/17 17 piece 1/2" A/F Deep Impact Socket Set part no 1800310

CIS12/10 1/2" Metric 6 point Impact Socket Set part no 3110875

CIS12/3M 3pc 1/2" drive non-slip socket set part no 1700732

CIS12/6SB 6-piece impact Spline socket set part no 1700726

---

## **GUARANTEE**

---

This product is guaranteed against faulty manufacture for a period of 12 months from the date of purchase. Please keep your receipt which will be required as proof of purchase.

This guarantee is invalid if the product is found to have been abused or tampered with in any way, or not used for the purpose for which it was intended.

Faulty goods should be returned to their place of purchase, no product can be returned to us without prior permission.

This guarantee does not effect your statutory rights.

# DECLARATION OF CONFORMITY



Fitzwilliam Hall, Fitzwilliam Place, Dublin 2

## DECLARATION OF CONFORMITY

This is an important document and should be retained.

We hereby declare that this product(s) complies with the following directive(s):  
2006/42/EC Machinery Directive.

The following standards have been applied to the product(s):  
EN / ISO 11148-6:2012.

The technical documentation required to demonstrate that the product(s) meet(s) the requirement(s) of the aforementioned directive(s) has been compiled and is available for inspection by the relevant enforcement authorities.

The CE mark was first applied in: 2019

**Product Description:** 1/2" Composite Air Impact Wrench  
**Model number(s):** CAT198  
**Serial / batch Number:** N/A  
**Date of Issue:** 09/02/2022

**Signed:**

J.A. Clarke  
Director



Hemmill Street, Epping, Essex CM16 4LG

## DECLARATION OF CONFORMITY

This is an important document and should be retained.

We hereby declare that this product(s) complies with the following statutory requirement(s):  
Supply of Machinery (Safety) Regulations 2008

The following standards have been applied to the product(s):  
BS EN ISO 11148-6:2012

The technical documentation required to demonstrate that the product(s) meet(s) the requirement(s) of the aforementioned legislation has been compiled and is available for inspection by the relevant enforcement authorities.

The UKCA mark was first applied in: 2022

**Product Description:** 1/2" Composite Air Impact Wrench  
**Model number(s):** CAT198  
**Serial / batch Number:** N/A  
**Date of Issue:** 09/02/2022

**Signed:**

J.A. Clarke  
Director

## COMPONENT PARTS LIST

No	Description
1	Main housing
2	O-ring
3	Trigger
4	Bolt
5	E-clip
6	Bearing
7	Rear plate
8	Cylinder
9	Bolt
10	Rotor
11	Spring
12	Rotor blade
13	Front plate
14	Bearing
15	Hammer cage
16	Hammer dog
17	Hammer pin
18	Anvil
19	O-ring
20	Retainer ring
21	Bushing

No	Description
22	Gasket
23	Front housing
24	Grease cap
25	Gasket
26	O-ring
27	Switch
28	Spring
29	Steel ball
30	O-ring
31	Rear cover
32	Set screw
33	Exhaust deflector
34	Cushion
35	Bolt
36	Circlip
37	Spacer
38	Oil seal
39	Tilt valve
40	Spring
41	O-ring
42	Air inlet
43	Extension bar

# COMPONENT PARTS DIAGRAM

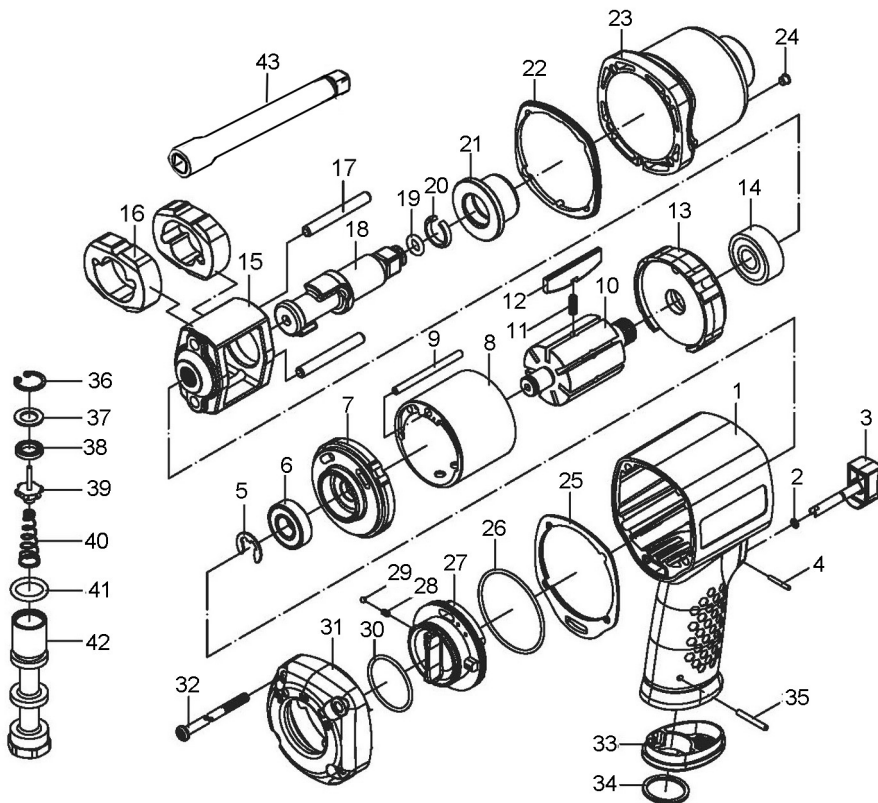

# A SELECTION FROM THE VAST RANGE OF

# Clarke®

## QUALITY PRODUCTS



### AIR COMPRESSORS

From DIY to industrial, Plus air tools, spray guns and accessories.

### GENERATORS

Prime duty or emergency standby for business, home and leisure.

### POWER WASHERS

Hot and cold, electric and engine driven - we have what you need

### WELDERS

Mig, Arc, Tig and Spot. From DIY to auto/industrial.

### METALWORKING

Drills, grinders and saws for DIY and professional use.

### WOODWORKING

Saws, sanders, lathes, mortisers and dust extraction.

### HYDRAULICS

Cranes, body repair kits, transmission jacks for all types of workshop use.

### WATER PUMPS

Submersible, electric and engine driven for DIY, agriculture and industry.

### POWER TOOLS

Angle grinders, cordless drill sets, saws and sanders.

### STARTERS/CHARGERS

All sizes for car and commercial use.

## PARTS & SERVICE:

## 0208 988 7400

### Parts Enquiries

[Parts@clarkeinternational.com](mailto:Parts@clarkeinternational.com)

### Servicing & Technical Enquiries

[Service@clarkeinternational.com](mailto:Service@clarkeinternational.com)

SALES: UK 01992 565333 or Export 00 44 (0)1992 565335

**Clarke** INTERNATIONAL Hemnall Street, Epping, Essex CM16 4LG  
[www.clarkeinternational.com](http://www.clarkeinternational.com)